

MultiONE™

1 Powerful Screw Multiple Materials

THE WORLD'S
MOST ADVANCED
SCREW.

A SCREW
& DRILL BIT
IN ONE.



See the MultiONE in action at
multi1.com.au



Innovation.
Engineering.
Manufacturing.
BREMICK®

PlaceMakers®

COUNTERSUNK TRUSS HEAD

Used where a flush finish is needed e.g. in timber or in a pre-countersunk fitting such as a shelf bracket.



- Suitable applications may include:
- Hardwood to softwood
 - Hardwood decking applications
 - Timber framing
 - Flooring systems
 - Cladding
 - Fencing
 - Builders brackets



MultiONE® Countersunk Truss Head	Product Code	Driver Bit	Pack Type	Pack Quantity	Screw Length (mm)	Axial Tensile (kN)	Single Shear (kN)	Torsional (Nm)
8g x 28mm B8® Coating	SVTRTU8080282S	T20	Enviro ⁺	80	28	6.2	5.8	5.9
	SVTRTU8080282T		Trade	250				
8g x 40mm B8® Coating	SVTRTU8080402S	T20	Enviro ⁺	60	40	6.2	5.8	5.9
	SVTRTU8080402T		Trade	200				
10g x 30mm B8® Coating	SVTRTU8100302S	T20	Enviro ⁺	60	30	10.6	8.3	11.4
	SVTRTU8100302T		Trade	200				
	SVTRTU8100302K		Bulk	500				
10g x 40mm B8® Coating	SVTRTU8100402S	T20	Enviro ⁺	50	40	10.6	8.3	11.4
	SVTRTU8100402T		Trade	150				
	SVTRTU8100402K		Bulk	500				
10g x 50mm B8® Coating	SVTRTU8100502S	T20	Enviro ⁺	35	50	10.6	8.3	11.4
	SVTRTU8100502T		Trade	125				
	SVTRTU8100502K		Bulk	250				
	SVTRTU8100502I		Bulk	500				
10g x 65mm B8® Coating	SVTRTU8100652S	T20	Enviro ⁺	25	65	10.6	8.3	11.4
	SVTRTU8100652T		Trade	100				
	SVTRTU8100652K		Bulk	250				
	SVTRTU8100652I		Bulk	500				
10g x 75mm B8® Coating	SVTRTU8100752S	T20	Enviro ⁺	20	75	10.6	8.3	11.4
	SVTRTU8100752T		Trade	75				
	SVTRTU8100752K		Bulk	200				
12g x 60mm B8® Coating	SVTRTU8120602S	T25	Enviro ⁺	20	60	14	9.6	13.5
	SVTRTU8120602T		Trade	100				
	SVTRTU8120602K		Bulk	250				
12g x 75mm B8® Coating	SVTRTU8120752S	T25	Enviro ⁺	16	75	14	9.6	13.5
	SVTRTU8120752T		Trade	75				
	SVTRTU8120752K		Bulk	200				
12g x 100mm B8® Coating	SVTRTU8121002S	T25	Enviro ⁺	12	100	14	9.6	13.5
	SVTRTU8121002T		Trade	50				
	SVTRTU8121002K		Bulk	200				
14g x 65mm B8® Coating	SVTRTU8140652S	T30	Enviro ⁺	12	65	20.3	11.1	20.8
	SVTRTU8140652T		Trade	75				
	SVTRTU8140652K		Bulk	200				
14g x 75mm B8® Coating	SVTRTU8140752S	T30	Enviro ⁺	10	75	20.3	11.1	20.8
	SVTRTU8140752T		Trade	60				
	SVTRTU8140752K		Bulk	200				
14g x 100mm B8® Coating	SVTRTU8141002S	T30	Enviro ⁺	8	100	20.3	11.1	20.8
	SVTRTU8141002T		Trade	50				
	SVTRTU8141002K		Bulk	150				



TORX® COMPATIBLE DRIVE

Positive bit engagement provides maximum application of torque

COUNTERSUNK TRUSS HEAD For secure and flush finish

TOPGRIP™ THREAD Locks materials together

UNIQUE THREAD DESIGN Engineered to fasten multiple materials with ease

HIGH TECH DRILL TIP Drills a perfect sized hole

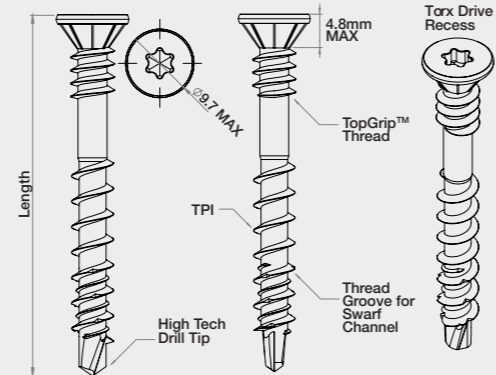

CONTOUR HEAD

Used when broad holding power &/or a decorative look is required. The underside of the head is flat & ideal for fixing sheet materials or heavier timbers.



- Suitable applications may include:
- Hardwood to softwood
 - Sheds & metal fencing
 - Cladding & screening
 - External fittings such as wall brackets, garden hose reels etc.
 - Aluminium signs



MultiONE® Contour Head	Product Code	Driver Bit	Pack Type	Pack Quantity	Screw Length (mm)	Axial Tensile (kN)	Single Shear (kN)	Torsional (Nm)
8g x 25mm B8® Coating	SVWSTU8080252S	T25	Enviro ⁺	60	25	6.2	5.8	5.9
	SVWSTU8080252T		Trade	250				
8g x 30mm B8® Coating	SVWSTU8080302S	T25	Enviro ⁺	50	30	6.2	5.8	5.9
	SVWSTU8080302T		Trade	200				
8g x 40mm B8® Coating	SVWSTU8080402S	T25	Enviro ⁺	40	40	6.2	5.8	5.9
	SVWSTU8080402T		Trade	150				
10g x 30mm B8® Coating	SVWSTU8100302S	T25	Enviro ⁺	40	30	10.6	8.3	11.4
	SVWSTU8100302T		Trade	150				
10g x 40mm B8® Coating	SVWSTU8100402S	T25	Enviro ⁺	35	40	10.6	8.3	11.4
	SVWSTU8100402T		Trade	125				
10g x 50mm B8® Coating	SVWSTU8100502S	T25	Enviro ⁺	25	50	10.6	8.3	11.4
	SVWSTU8100502T		Trade	100				
	SVWSTU8100502K		Bulk	250				
	SVWSTU8100502I		Bulk	500				
10g x 65mm B8® Coating	SVWSTU8100652S	T25	Enviro ⁺	20	65	10.6	8.3	11.4
	SVWSTU8100652T		Trade	75				
	SVWSTU8100652K		Bulk	200				
12g x 60mm B8® Coating	SVWSTU8120602S	T30	Enviro ⁺	12	60	14	9.6	13.5
	SVWSTU8120602T		Trade	75				
	SVWSTU8120602K		Bulk	200				
12g x 75mm B8® Coating	SVWSTU8120752S	T30	Enviro ⁺	10	75	14	9.6	13.5
	SVWSTU8120752T		Trade	60				
	SVWSTU8120752K		Bulk	150				
12g x 100mm B8® Coating	SVWSTU8121002S	T30	Enviro ⁺	8	100	14	9.6	13.5
	SVWSTU8121002T		Trade	50				
	SVWSTU8121002K		Bulk	150				
14g x 65mm B8® Coating	SVWSTU8140652S	T30	Enviro ⁺	10	65	20.3	11.1	20.8
	SVWSTU8140652T		Trade	60				
	SVWSTU8140652K		Bulk	150				
14g x 75mm B8® Coating	SVWSTU8140752S	T30	Enviro ⁺	8	75	20.3	11.1	20.8
	SVWSTU8140752T		Trade	50				
	SVWSTU8140752K		Bulk	125				
14g x 100mm B8® Coating	SVWSTU8141002S	T30	Enviro ⁺	6	100	20.3	11.1	20.8
	SVWSTU8141002T		Trade	40				
	SVWSTU8141002K		Bulk	100				



TORX® COMPATIBLE DRIVE

Positive bit engagement provides maximum application of torque

CONTOUR HEAD Broad holding powers means materials are brought together and held in position, resisting warp and head pull through

UNIQUE THREAD DESIGN Engineered to fasten multiple materials with ease

HIGH TECH DRILL TIP Drills a perfect sized hole

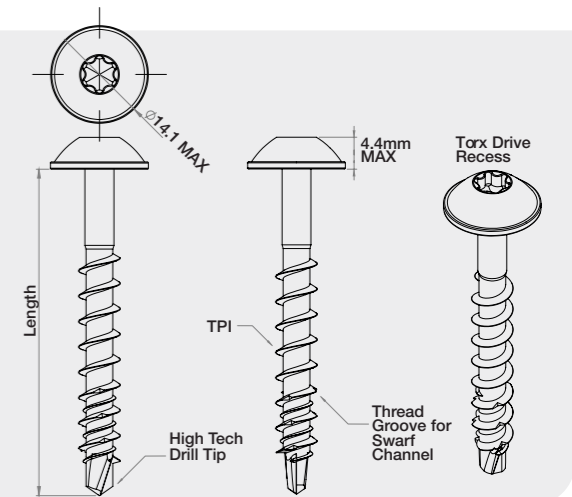

*Torx is a registered trademark owned by Acument Intellectual Properties, LLC

MASONRY FIXING DETAILS & Axial Withdrawal Loads from Timber & Metal*

BREMICK®

Screw Size	Min. Timber Embed.‡ Depths (mm)		Axial Withdrawal Forces (kN)			Masonry						
	F5 (Softwood) Radiata Pine	F17 Hardwood	F5 (Softwood) Radiata Pine 30mm Embed.	F17 Hardwood: 30mm Embed.	1.5mm BMT G450 Steel Purlin	Pilot hole diameter (mm)	MIN Pilot hole Depth (mm)	MIN Embed.‡ Depth (mm)	Clamping Capacity 'Truss' Head (max)	Clamping Capacity Contour Head (max)	Max Safe Load in 25MPA Concrete (kG)*	Max Load in Extruded Common Brick (kG)*
10x30	25	20	3.5	7.1	3.6	4mm	50	25mm	2mm	5mm	86	78
10x40	30	25	3.5	7.1	3.6	4mm	60	25mm	12mm	15mm	86	78
10x50	35	30	3.5	7.1	3.6	4mm	70	25mm	22mm	25mm	86	78
12x60	35	30	3.7	7.5	3.9	5mm	70	35mm	30mm	35mm	105	96
12x75	45	35	3.7	7.5	3.9	5mm	95	35mm	50mm	55mm	105	96
12x100	65	50	3.7	7.5	3.9	5mm	120	35mm	70mm	75mm	105	96

‡Embedment Depths Minimum Embedment is the amount of screw that is embedded into the material that you are fixing to.

* Notes: 1. Safe load has been calculated using a 4:1 safety factor. 2. Safe loads are a guideline only and are not guaranteed. 3. The Data in the table represents characteristic data obtained under laboratory conditions and only apply to the Bremick MultiONE™ products. Appropriate safety factors must be applied.

THE RANGE complies with AS3566

HEAD TYPE	SIZE (mm)	BREMICK SKU	PLACEMAKERS SKU	DESCRIPTION	DRIVE BIT	PACK QTY
COUNTERSUNK TRUSS HEAD	10g x 30	SVTRTU8100302T	4512644	MULTIONE TRUSS HD TORX 20 10G X 30 B8 PK200	T20	200
	10g x 40	SVTRTU8100402T	4512645	MULTIONE TRUSS HD TORX 20 10G X 40 B8 PK150	T20	150
	10g x 50	SVTRTU8100502T	4512647	MULTIONE TRUSS HD TORX 20 10G X 50 B8 PK125	T20	125
	10g x 50	SVTRTU8100502K	4512648	MULTIONE TRUSS HD TORX 20 10G X 50 B8 PK250	T20	250
	10g x 65	SVTRTU8100652T	4512649	MULTIONE TRUSS HD TORX 20 10G X 65 B8 PK100	T20	100
	10g x 65	SVTRTU8100652K	4512650	MULTIONE TRUSS HD TORX 20 10G X 65 B8 PK250	T20	250
	10g x 75	SVTRTU8100752T	4512651	MULTIONE TRUSS HD TORX 20 10G X 75 B8 PK75	T20	75
	10g x 75	SVTRTU8100752K	4512652	MULTIONE TRUSS HD TORX 20 10G X 75 B8 PK200	T20	200
	12g x 60	SVTRTU8120602T	4512654	MULTIONE TRUSS HD TORX 25 12G X 60 B8 PK100	T25	100
	12g x 60	SVTRTU8120602K	4512655	MULTIONE TRUSS HD TORX 25 12G X 60 B8 PK250	T25	250
	12g x 75	SVTRTU8120752T	4512656	MULTIONE TRUSS HD TORX 25 12G X 75 B8 PK75	T25	75
	12g x 75	SVTRTU8120752K	4512657	MULTIONE TRUSS HD TORX 25 12G X 75 B8 PK200	T25	200
CONTOUR HEAD	12g x 100	SVTRTU8121002T	4512658	MULTIONE TRUSS HD TORX 25 12G X 100 B8 PK50	T25	50
	12g x 100	SVTRTU8121002K	4512659	MULTIONE TRUSS HD TORX 25 12G X 100 B8 PK200	T25	200
	10g x 30	SVWSTU8100302T	4512660	MULTIONE CONTOUR HD TORX 25 10G X 30 B8 PK150	T25	150
	10g x 40	SVWSTU8100402T	4512662	MULTIONE CONTOUR HD TORX 25 10G X 40 B8 PK125	T25	125
	10g x 50	SVWSTU8100502T	4512663	MULTIONE CONTOUR HD TORX 25 10G X 50 B8 PK100	T25	100
	10g x 50	SVWSTU8100502K	4512664	MULTIONE CONTOUR HD TORX 25 10G X 50 B8 PK250	T25	250
	10g x 65	SVWSTU8100652T	4512665	MULTIONE CONTOUR HD TORX 25 10G X 65 B8 PK75	T25	75
	10g x 65	SVWSTU8100652K	4512666	MULTIONE CONTOUR HD TORX 25 10G X 65 B8 PK200	T25	200
	12g x 60	SVWSTU8120602T	4512667	MULTIONE CONTOUR HD TORX 30 12G X 60 B8 PK75	T30	75
	12g x 60	SVWSTU8120602K	4512668	MULTIONE CONTOUR HD TORX 30 12G X 60 B8 PK200	T30	200
	12g x 75	SVWSTU8120752T	4512669	MULTIONE CONTOUR HD TORX 30 12G X 75 B8 PK60	T30	60
	12g x 75	SVWSTU8120752K	4512670	MULTIONE CONTOUR HD TORX 30 12G X 75 B8 PK150	T30	150
12g x 100	SVWSTU8121002T	4512671	MULTIONE CONTOUR HD TORX 30 12G X 100 B8 PK50	T30	50	
12g x 100	SVWSTU8121002K	4512672	MULTIONE CONTOUR HD TORX 30 12G X 100 B8 PK150	T30	150	

PACKAGING

Screw plastic!

Packaging is 100% recyclable and re-usable cardboard. For more information on recycling visit www.arl.org.au



INTERNATIONAL PATENT PENDING

Available through



CONTACT US

New Zealand (Auckland) E nthnzsales@bremick.co.nz P 9525 2244

New Zealand (Christchurch) E sthnzsales@bremick.co.nz P 3365 8998